

Strategies for argument and adjunct focalization in Basque

Aritz Irurtzun
CNRS – IKER, UMR5478

In this chapter, I provide an overview of the different strategies employed for *Wh*-questions and focalizations across Basque dialects. I argue that a core property of Basque syntax is the fact that both *Wh*- and focus phrases undergo syntactic (*A'*-type) displacements, and that they exhibit the main characteristics of syntactic displacements (locality, successive cyclicity, sensitivity to islands, etc.). After analysing the “standard strategy”, which is available across all dialects, I provide an overview of the new *in situ Wh*-question strategy of the young speakers of Navarro-Labourdin and two different strategies that are employed across different dialects to generate reinforced foci: the highly contrastive rightward focus constructions (specific to Southern dialects, and particularly common in High Navarrese), and the ‘reinforced movement’ strategy of Navarro-Labourdin (a Northern variety). I finish with a brief description of some other constructions involving foci: the mirative focus constructions of substandard Basque, and the dialectal distribution of different types of split interrogatives.

Keywords: focus; *Wh*-movement; left periphery; *wh in situ*

1. Introduction: The ‘Standard Strategy’¹

Basque has been characterized as a S-IO-DO-V language given that, even if the order of constituents in this language is not a fixed one, this is the pattern appearing in an out-of-the-blue or all-new statement (*cf.*, *i.a.*, Ortiz de Urbina,

1. My deepest thanks to B. Fernández and J. Ortiz de Urbina for their editorial support and to two anonymous reviewers for their insightful comments. This work benefited from the projects IT769-13 (Eusko Jaurlaritza), FFI2013-43823-P, FFI2013-41509-P and FFI2014-53675-P (MINECO). The research leading to these results has also received funding from the European Union’s Seventh Framework Programme for research, technological development and demonstration under grant agreement n^o 613465.

1989 *et seq.*; Elordieta, 2001; Etxepare and Ortiz de Urbina, 2003; Irurtzun, 2007; Erdozia et al., 2009). However, information-structure affects the order of constituents in Basque and it is, therefore, a ‘discourse-configurational’ language (in the sense of Kiss 1995). In this chapter, I provide an overview of the main syntactic and semantic properties of different question and focalization strategies in Basque. The discussion will concentrate on *Wh*-questions and argument and adjunct focalization – what is known as “term-focus”–, see Elordieta and Haddican (this volume) for an analysis of verb-focalization and Elordieta and Irurtzun (2010) for a study involving *verum* focus.

To begin with, there is in Basque a common *Wh*-movement and focalization strategy that we could term the ‘standard strategy’, for it is available across all dialects of this language. This strategy is exemplified in (1b) for a *Wh*-question and (1c) for a subject-focalization, where we can observe that the basic S-O-V word order of an *out-of-the-blue* statement (1a) is altered and the verb appears immediately following the *Wh*- (1b) or focal (1c) phrase:

- (1) a. Jonek ura edan du
 Jon water drink AUX
 ‘Jon drank water’
 b. Nork edan du ura?
 who drink AUX water
 ‘Who drank water?’
 c. [Jonek]_F edan du ura
 Jon drink AUX water
 ‘[Jon]_F drank water’

Actually, a long-standing observation in Basque linguistics (*cf. i.a.* Altube 1920; de Rijk 1969; Mitxelena 1981; Eguzkitza 1987; Ortiz de Urbina 1989; Rebuschi 1997; Artiagoitia 2000) is that if this change in word order does not take place, the result is ungrammatical, as illustrated in the examples in (2a,b):

- (2) a. *Nork ura edan du?
 who water drink AUX
 ‘Who drank water?’
 b. *[Jonek]_F ura edan du
 Jon water drink AUX
 ‘[Jon]_F drank water’

Authors like Ortiz de Urbina (1989, *et seq.*) or Irurtzun (2007) have analysed these constructions as involving an A’-displacement of the relevant phrase (a *Wh*-phrase or a focal phrase) to the specifier of some functional projection at

the left periphery of the clause (traditionally, taken to be C° or Foc°).² This displacement in turn would be followed by a T-to-C movement, as represented in (3), which, in order to avoid repeating the same tree twice, combines the structure under the subject-question in (1b) and the subject-focalization in (1c) (for simplicity, I am omitting the movement of the subject DP from $\text{Spec-}\nu\text{P}$ to Spec-TP , and the movement of V-to- ν -to-T):³

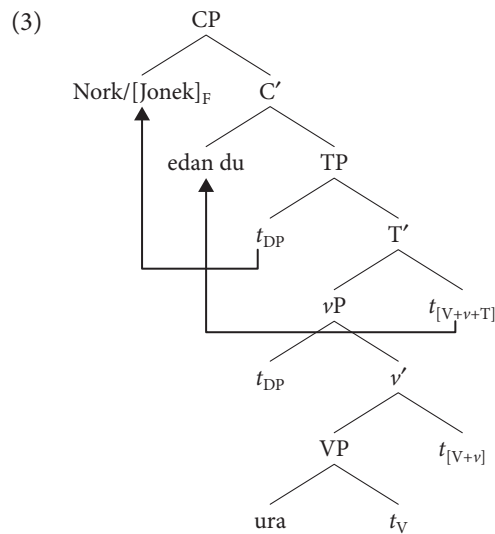

1.1 Cyclicity

Furthermore, we can observe the cyclic nature of the *Wh*- or focus movement in embedded clauses in that the extraction of (for instance) the subject of an embedded clause is always accompanied by the movement of the verb, both in matrix and embedded clauses. If the movement of the embedded verb does not take place, the result is ungrammatical. Departing from the neutral (4a), the necessity of verb-movement can be observed in the contrast between sentences (4b) and (4c), for *Wh*-extraction, and between (4d) and (4e) for focalization:⁴

2. See also Elordieta (2001) and Arregi (2002) for alternative proposals and Artiagoitia (2000) and Etxepare and Ortiz de Urbina (2003) for a general overview of the syntax of these constructions.

3. See also Laka and Uriagereka (1987) and Uriagereka (1999) among others.

4. A reviewer wonders whether all speakers find these examples ungrammatical. The literature converges in this direction and the speakers I have consulted tend to associate the word

- (4) a. Jonek [Mirenek ura edan duela] esan du
Jon Miren water drink AUX.C say AUX
'Jon said that Miren drank water'
- b. Nork esan du Jonek [*t* edan duela ura]?
who say AUX Jon drink AUX.C water
'Who did Jon say that drank water?'
- c. *Nork esan du Jonek [*t* ura edan duela]?
who say AUX Jon water drink AUX.C
'Who did Jon say that drank water?'
- d. [Mirenek]_F esan du Jonek [*t* edan duela ura]
who say AUX Jon drink AUX.C water
'Jon said that [Miren]_F drank water'
- e. *[Mirenek]_F esan du Jonek [*t* ura edan duela]
Miren say AUX Jon water drink AUX.C
'Jon said that [Miren]_F drank water'

In both (4b) and (4c) we have a *Wh*-question over the subject of the embedded clause; the only difference between both clauses is that in (4b) we observe OV inversion in the embedded clause (along with the SV inversion of the matrix clause), but in (4c) we do not, resulting in ungrammaticality. Likewise for the focalization constructions in (4d) and (4e). The necessity of verb-movement in the embedded clause has been taken as an indication that the extracted element moves through the specifier of the embedded CP in its way to the specifier of the matrix CP, this cyclic movement being the catalyst of the verb-movement in the embedded clause.⁵ Therefore, the derivation corresponding to (4b)-(4d) would be the one in (5):

order in (4c) not with the interpretation in (4c) but with a reading where extraction does not take place from the embedded clause but from the matrix clause ('Who said that John drank water?'). Unfortunately, we still lack any formal experimental test on acceptability judgements for this type of data.

5. See *Ortiz de Urbina* (1995) for an analysis.

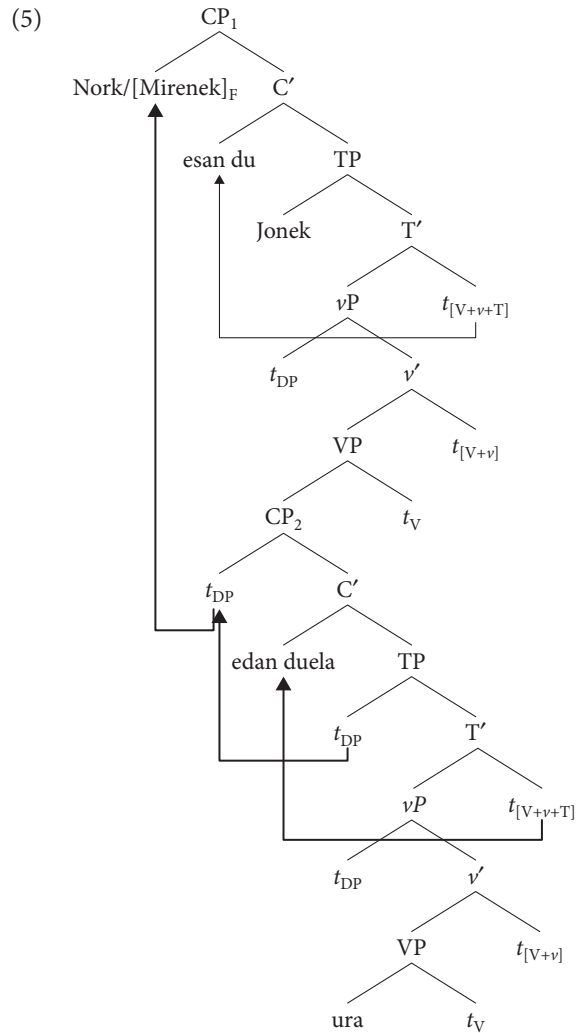

Importantly, Basque is well-known for also having an alternative to long distance extraction: clausal pied-piping (*cf.* Ortiz de Urbina 1989, 1993; Arregi 2003; Irurtzun 2007). Consider the data in (6) for *Wh*-questions and (7) for focalizations. In (6a,7a) we observe that the whole embedded clause is fronted to the left periphery of the matrix CP, and that there is OV inversion in the embedded clause, and SV inversion in the matrix clause, which results in a perfectly grammatical sentence. Lack of inversion (*i.e.*, lack of T-to-C movement) in the matrix clause (6b,7b) or the embedded clause (6c,7c) results in ungrammaticality, as does the lack of inversion in both matrix and embedded clauses (6d,7d):

- (6) a. [Nork edan duela ura] esan du Jonek?
 who drink AUX.C water say AUX Jon
 ‘Who did Jon say that drank water?’
- b. *[Nork edan duela ura] Jonek esan du?
 who drink AUX.C water Jon say AUX
 ‘Who did Jon say that drank water?’
- c. *[Nork ura edan duela] esan du Jonek?
 who water drink AUX.C say AUX Jon
 ‘Who did Jon say that drank water?’
- d. *[Nork ura edan duela] Jonek esan du?
 who water drink AUX.C Jon say AUX
 ‘Who did Jon say that drank water?’
- (7) a. [[Mirenek]_F edan duela ura] esan du Jonek
 Miren drink AUX.C water say AUX Jon
 ‘Jon said that [Miren]_F drank water’
- b. *[[Mirenek]_F edan duela ura] Jonek esan du.
 Miren drink AUX.C water Jon say AUX
 ‘Jon said that [Miren]_F drank water’
- c. *[[Mirenek]_F ura edan duela] esan du Jonek
 Miren water drink AUX.C say AUX Jon
 ‘Jon said that [Miren]_F drank water’
- d. *[[Mirenek]_F ura edan duela] Jonek esan du
 Miren water drink AUX.C Jon say AUX
 ‘Jon said that [Miren]_F drank water’

Thus, the analysis of the derivation of clausal pied-piping structures is very similar to that of long distance extractions. As a first step, the *Wh*-phrase/focus phrase is moved to the specifier of the embedded clause, attracting its verbal complex, and then, instead of extracting it to the specifier of the matrix CP (as in the long distance extraction in (5)), it is the whole embedded CP that is moved to the specifier of the matrix CP, generating T-to-C movement in the matrix clause, as represented in (8), which corresponds to examples (6a) and (7a):

(8)

Step 1:

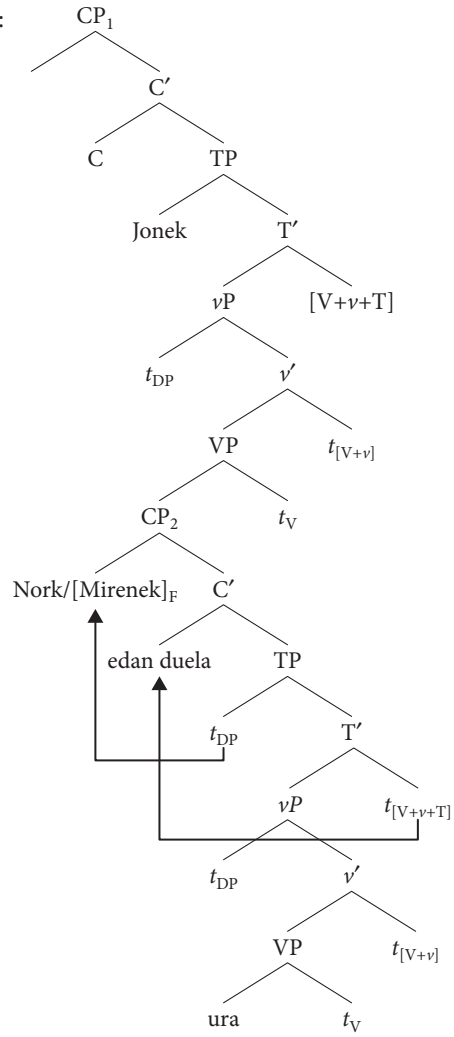

Step 2:

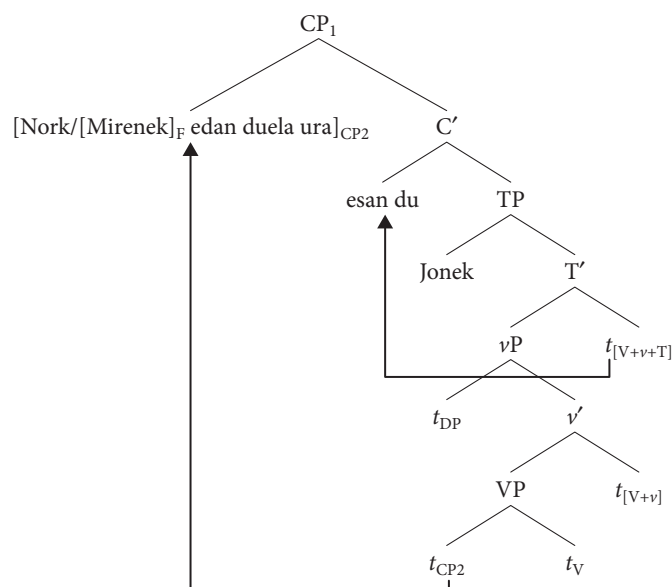

Finally, let me note that the parasitic movement of the verb with respect to the *Wh*-movement can serve as a disambiguator of scope for extractions that could be potentially ambiguous. This is, for instance, the case of modifiers like *noiz* (when) that could, potentially, be first-merged in either the matrix or the embedded clause, as in the examples in (9):

- (9) a. Noiz pentsatzen duzu [gerra bukatuko dela]?
 when think aux war finish AUX.C
 ‘When is it that you think that the war will finish?’ (When→think)
- b. Noiz pentsatzen duzu [bukatu ko dela gerra]?
 when think aux finish AUX.C war
 ‘According to you, when will the war finish?’ (When→finish)

A direct consequence of the parasitic nature of verb-movement is that a focus or interrogative displacement of an element in the matrix clause generates no inversion in the embedded clause (9a), but on the contrary, extraction from the embedded clause is accompanied by T-to-C movement in both embedded and matrix clauses (9b). As a consequence, the scopal properties of the interrogative have a direct mapping in the syntactic structure of the clause. As a matter of fact, a plausible answer to question (9a) could be something like “Whenever I see the occupation troops leaving the city” (*i.e.* that’s when I think that the war will come to an end), and a plausible answer to question (9b) something like “When the last city will be liberated” (*i.e.* I think that when such an event will be accomplished, the war will come to an end).

Now, let us give a look at some of the syntactic restrictions that are inherent to the displacement operations in questions and focalizations.

1.2 Islandhood restrictions

We just saw that the displacements underlying questions and focalizations in Basque observe some locality and cyclicity restrictions which are shown with the movement of the verbal complex. However, these are not the only characteristic restrictions of *Wh*-questions and foci. In fact, given that they involve *A'*-displacements, *Wh*-questions and focalizations are also sensitive to various sorts of syntactic islands. For instance, extraction out of a coordination phrase results in plain ungrammaticality. This is illustrated in (10b,c):

- (10) a. Jonek [salda eta legatza] nahi ditu
 Jon stock and hake want AUX
 'Jon wants stock and hake'
- b. *Zer nahi ditu Jonek [salda eta t]?
 what want AUX Jon stock and
Lit. 'What does Jon want stock and?'
- c. *Zer nahi ditu Jonek [t eta legatza]?
 what want AUX Jon and hake
Lit. 'What does Jon want and hake?'
- (11) a. *[Legatza]_F nahi du Jonek [salda eta t]
 hake want AUX Jon stock and
 'Jon wants stock and [hake]_F'
- b. *[Salda]_F nahi du Jonek [t eta legatza]
 stock want AUX Jon and hake
Lit. 'What does Jon want and hake?'

And the same happens with extraction out of adjuncts (12b,c), left branch phrases (13b,c) or complex NPs (14b,c); *Wh*- or focus movement out of these islands derives in ungrammaticality:

- (12) a. Jon [abestia entzun duelako] poztu da
 Jon song hear AUX.because get.happy AUX
 'Jon got happy because he heard the song'
- b. *Zer poztu da Jon [t entzun duelako]?
 what get.happy AUX Jon hear AUX.because
Lit. 'What did Jon got happy because he heard?'
- c. *[Abestia]_F poztu da Jon [t entzun duelako]
 song get.happy AUX Jon hear AUX.because
Lit. 'Jon got happy because he heard [the song]_F'
- (13) a. Mirenek [Jonen liburua] irakurri du
 Miren Jon's book read AUX
 'Miren read Jon's book'

- b. *Noren irakurri du Mirenek [*t* liburua]?
 whose read AUX Miren book
 ‘Whose book did Miren read?’
- c. *[Jonen]_F irakurri du Mirenek [*t* liburua]
 Jon’s read AUX Miren book
 ‘Miren read [Jon’s]_F book’
- (14) a. [Jonek liburu bat idatzi duelako zurrumurrua] entzun duzu
 Jon book one write AUX.C.P rumour hear aux
 ‘You heard the rumour that Jon wrote a book’
- b. *Zer entzun duzu [Jonek *t* idatzi duelako zurrumurrua]?
 what hear AUX Jon write AUX.C.P rumour
Lit. ‘What did you hear the rumour that Jon wrote?’
- c. *[Liburu bat]_F entzun dut [Jonek *t* idatzi
 book one hear AUX Jon write
 duelako zurrumurrua]
 AUX.C.P rumour
 ‘I heard the rumour that Jon wrote [a book]_F’

So, as we said, all these restrictions constitute evidence that both *Wh*-questions and focalizations in Basque have a very similar syntax. In a nutshell, they both involve:

- i. A'-movement of the focus/*Wh*-phrase to Spec-CP.⁶
- ii. T-to-C movement, which renders adjacency between the verbal complex (V+v+T) and the moved phrase.
- iii. Cyclicity in the focus/*Wh*-movement, which can be observed in the cyclic movement of the verbal complex of each clause.
- iv. A ban on extraction out of islands.
- v. Possible clausal pied-piping.

This is the panoramic picture regarding the standard constructions.⁷ In the next sections, I will present the microparametric variability observed in the *Wh*-question and focalization strategies employed across Basque dialects. Section 2 will briefly present the emergent *Wh in situ* strategy of Labourdin Basque, Section 3 will be devoted to two ‘reinforced focus’ constructions ((i) the “rightward” focalization

6. Or Spec-FocP in “split CP” analyses (see, e.g. Ortiz de Urbina 1999; Irurtzun 2007).

7. An anonymous reviewer reminds me that Elordieta (2001) mentions a potential point of variation between focalizations and *Wh*-constructions with respect to “weak crossover” effects (focalizations would generate a weaker agrammaticality effect than *Wh*-constructions). The observation is interesting but the phenomenon and judgments are not clear, and unfortunately we still have no in-depth study of this important issue.

strategy of Southern dialects and (ii) the “movement+AUX” construction of Northern dialects), and Section 4 will briefly present some other focus constructions attested in Basque dialects: a substandard mirative focus construction, and two different split interrogatives, which vary in their geographic distribution. Again, it should be emphasized that even if I will be dealing with some strategies that are restricted to some varieties, all varieties of Basque have the standard strategy that we just saw, and that the alternative strategies that I will comment on in the next sections are employed along with the standard ones (in fact, they are typically employed to convey different semantic nuances).

2. The new *wh in situ* strategy of Navarro-Labourdin Basque

Recently, Duguine and Irurtzun (2014) have discovered that young speakers of Navarro-Labourdin Basque also have another type of *Wh*-question construction, which is unavailable to older speakers of this dialect, and to the speakers of other dialects in Southern Basque Country (in the Spanish territory). This strategy is illustrated in examples (15) and (16):

(15) Nork gereziak jan ditu?
 who cherries eat AUX
 ‘Who ate the cherries?’

(16) Jonek zer fite jan du?
 Jon what quickly eat AUX
 ‘What did Jon eat quickly?’

In these constructions, we do not observe the typical adjacency between the *Wh*-phrase and the verb, characteristic of standard strategies (in (15) the DO appears between the interrogative subject and the verb, and in (16) the adverb ‘fite’ (quickly) is sandwiched between the interrogative DO and the verb). Duguine and Irurtzun’s (2014) analysis is that underlying these examples there is an *in situ Wh*-strategy. In fact, in these constructions no interrogative displacement seems to take place (no *Wh*-movement and, as a consequence, no residual V2 effect), but furthermore, these constructions of Navarro-Labourdin Basque also share a range of properties with French *wh in situ*. In particular, they display intervention effects with negation: *Wh in situ* constructions are ungrammatical when the *Wh*-phrase is c-commanded by negation (17), the only way of asking a question with negation on the matrix clause being the *Wh*-movement strategy (18) (see Bošković 1998, 2000 or Mathieu 1999, 2004 for French data and analysis):

(17) *Jonek ez du zer jaten?
 Jon NEG AUX what eat
 ‘What doesn’t Jon eat?’

- (18) Zer ez du jaten Jonek?
 what NEG AUX eat Jon
 ‘What doesn’t Jon eat?’

Furthermore, these *wh in situ* constructions also pattern like French *wh in situ* paradigms regarding *Wh*-islands: *Wh*-phrases cannot remain *in situ* in *Wh*-islands (19), while they can move out of them (20):

- (19) *Ba-dakizu [nola nori opari bat eskaini]?
 yes-know how who present a offer
 ‘Do you know how to give a present to whom?’
- (20) Nori ez dakizu [nola eskaini opari bat]?
 who NEG know how offer present a
 ‘Who don’t you know how to give a present to?’

Last, another characteristic property of *Wh in situ* constructions in French is that they can be embedded within strong islands (*cf.* Obenauer 1994; Shlonsky 2012). The *in situ Wh* constructions of Navarro-Labourdin Basque also show the same asymmetry: while regular *Wh*-movement displays island effects (21), *Wh in situ* constructions are just mildly deviant when embedded within strong islands (22):

- (21) *Nori piztu dute jendearen kexua [t etxea kentzean]?
 who light AUX people.of anger house remove.when
Lit. ‘Who did they lit people’s anger when they took the house to?’
- (22) ??[Nori etxea kentzean] jendearen kexua piztu dute?
 who house remove.when people.of anger light AUX
Lit. ‘They lit people’s anger when they took the house to who?’

The syntactic and semantic similarity of these constructions with respect to the French *Wh in situ* has led Duguine and Irurtzun (2014) to the hypothesis that a catalyst for its emergence in Labourdin Basque is a transfer from French (which would be made possible by other 3rd factor effects like an innate bias for preferring movementless operations).

In the next section I will briefly present two strategies that are employed for ‘reinforced focalizations’ across Basque dialects: the ‘rightward focalization’ of Southern dialects (3.1), and the ‘displacement+auxiliary’ constructions of Navarro-Labourdin (3.2).

3. Reinforced focus strategies

In this section I give an overview of some ‘reinforced’ focalization strategies observed across Basque dialects. Generally these strategies are termed ‘reinforced’

also explain some scopal relations that would otherwise be hard to explain. Consider the rightward focus construction of (26), where the focal XP takes scope over negation, linear order notwithstanding:

- (26) Ez da etorri [horregatik]_F
 not AUX come because.of.that
 ‘He did not come [because of that]_F’
 (= [That]_F, and not (the) other one, is the reason why he did not come).

On this approach, we expect negation not to take scope over the focal *horregatik*, for Neg^o is contained within the remnant-moved phrase and from there it cannot c-command the purpose-clause *horregatik*. The availability of the remnant movement operation (25b) would be restricted to Southern varieties of Basque, which would account for the restricted distribution of these constructions.⁸

3.2 The ‘movement+AUX’ strategy of Navarro-Labourdin

The Navarro-Labourdin dialect does not generally display the rightward focalization strategy, but it has a different reinforced construction to express exhaustive focalization: the movement+AUX construction. This construction, which coexists in Navarro-Labourdin with the standard construction, is characterized by involving a ‘canonical’ *Wh*-movement to Spec-CP but instead of being accompanied by movement of the verbal complex to C^o, it only involves movement of the auxiliary to T. This is illustrated in (27b), a reinforced variant of the standard (27a):⁹

- (27) a. [Mirenek]_F galdegin du izokina [Standard focus construction]
 Miren ask AUX salmon
 ‘[Miren]_F ordered salmon’
 b. [Mirenek]_F du izokina galdegin. [Reinforced construction]
 Miren AUX salmon ask
 ‘It’s [Miren]_F that ordered salmon’

This is a construction that is restricted to main clauses, and according to the analysis in Duguine and Irurtzun (2010), the reinforced nature of these constructions

8. It should be noted that the speakers of these varieties of Basque (all Spanish-Basque bilinguals) also have a very similar construction in Spanish, namely, the non-echoic sentence-final *Wh*-questions (cf. Uribe-Etxebarria 2002; Etxepare and Uribe-Etxebarria 2004).

9. I translate example (27b) with a cleft in order to express the reinforced nature of these constructions. Actually, Lafitte (1944: 48) when commenting on these constructions says that ‘pour le traduire, le français *ce que* est obligatoire’ [in order to translate it, French *ce que* is necessary]. See Duguine and Irurtzun (2010) for discussion.

is clearly observed in their semantic interpretation regarding the parameters of presuppositionality and exhaustivity.¹⁰ For instance, even if all *Wh*-questions take as granted that the eventuality described in the question takes place, the presupposition of reinforced constructions is stronger, and a discourse clash or clear incongruence is generated when the presupposition is refuted. Consider the data in (28) and (29). In (28) we observe that the presupposition of the *Wh*-question in (28A) is directly refuted in the answer in (28B), but there is no sharp discourse clash. On the contrary, the refutation in (29B) clashes directly with the presupposition expressed in the reinforced *Wh*-question in (29A), as it would do with a clefted question in English:

- (28) A: Zer jan duzu? [Standard *Wh*-construction]
 what eat AUX
 ‘What did you eat?’
 B: Deus ez
 nothing not
 ‘I ate [nothing]_F’
- (29) A: Zer duzu jan? [Reinforced *Wh*-construction]
 what AUX eat
 ‘What is it that you ate?’
 B: #Deus ez
 nothing not
 ‘It’s [nothing]_F that I ate’

Likewise, reinforced interrogative and focus constructions always require a strongly exhaustive or complete answer interpretation (*cf.* Duguine and Irurtzun 2010). Thus, contrary to standard constructions, they cannot appear with additive particles (30), and they cannot be employed in a pair-list answer (31):

10. The restriction to main clauses makes that extraction out of embedded clauses using this strategy renders ungrammaticality, as represented in (i), with the reinforced strategy only in the embedded clause, and (ii), with the embedded strategy in both clauses:

- (i) *[Mirenek]_F erran dut [t duela Jon ikusi]
 Miren say AUX AUX.C Jon see
 ‘I said that Jon saw [Miren]_F’
- (ii) *[Mirenek]_F dut erran [t duela Jon ikusi]
 Miren AUX say AUX.C Jon see
 ‘I said that Jon saw [Miren]_F’

- (30) a. Nor besterik jinen da? [Standard *Wh*-construction]
 who else come.FUT AUX
 ‘Who else will come?’
- b. *Nor besterik da jinen? [Reinforced *Wh*-construction]
 who else AUX come.FUT
 ‘Who else is it that will come?’
- (31) a. Jon jinen da, Peio jinen da... [Standard
 Jon come.FUT AUX Peio come.FUT AUX *Wh*-construction]
 ‘Jon will come, Peio will come...’
- b. *Jon da jinen, Peio da jinen... [Reinforced
 Jon AUX come.FUT Peio AUX come.FUT *Wh*-construction]
 ‘It’s Jon that will come, it’s Peio that will come...’

The availability of this strategy, as I said, is restricted to Northern dialects, and it may be correlated with a range of other phenomena involving participial periphrases (*cf.* Etxepare 2014 for a recent microparametric analysis).

Having briefly analysed the reinforced constructions, in Section 4 I will overview two other focus constructions; a substandard mirative construction of Southern Basque, and two split interrogative (*Wh*-question+focus) constructions, one of them available to all speakers across Basque dialects, the other one restricted to Southern dialects.

4. Other Constructions

Along with the standard and reinforced constructions of each dialect, there are also other constructions which, even though not evenly spread across the population deserve a brief mention here, given that they also have characteristic correspondences between their syntactic form and their semantic interpretation. Here I would like to briefly comment on two of these constructions; the mirative focus (Section 4.1), and the split interrogative constructions (Section 4.2.).

4.1 Mirative focus constructions

Mirativity in Basque has not got an in-depth treatment in the literature, and its grammatical status is not very clear. However, Etxepare (1998) discusses some constructions that, even though they are not fully grammaticalised nor evenly spread across the population, can be taken as instances of “mirative focus” constructions. Etxepare (1998) concentrates on the differences between the type of focus constructions like (32) that we have seen in Section 1, and

position and the focus (the potential answer) in sentence-final position. This is illustrated in (34):

- (34) Zer nahi du Jonek, [ogia]_F?
 what.ABS want AUX Jon bread.ABS
 Is it the bread that Jon wants? (*Lit.* ‘What does Jon want, the bread?’)

Irurtzun (2014) argues that we have to distinguish two types of split questions. On the one hand, we would have *matching questions*, where the *Wh*-phrase to the left matches in syntactic type and semantic interpretation with the focus phrase to the right. (35) would be a canonical example of a matching construction where the focal element to the right bears the same case (ergative) and theta-role as the fronted *Wh*-phrase:

- (35) Nork egin du, [Jonk]_F? [Matching type]
 who.ERG make AUX Jon.ERG
 ‘Was it [Jon]_F that made it?’ (*Lit.* ‘Who made it, Jon?’)

These constructions are common to all dialects of Basque. On the other hand, we have *what-type* questions; constructions that invariably show the dummy interrogative pronoun *zer* (what) to the left, which does not match with the focal phrase (36). These are restricted to the Southern dialects:

- (36) a. Zer egin du, [Jonk]_F? [What type]
 what make AUX Jon.ERG
 ‘Was it [Jon]_F that made it?’ (*Lit.* ‘What made it, Jon?’)
 b. Zer zatoz, [bihar]_F? [What type]
 what come tomorrow
 ‘Is it [tomorrow]_F that you are coming?’
 (*Lit.* ‘What are you coming, tomorrow?’)

According to Irurtzun (2014), *matching type* split interrogatives are derived from a simple bi-clausal construction: a regular *Wh*-question followed by a leftward focalization which undergoes sluicing (following the analysis of Spanish *matching* constructions proposed by Arregi 2010). Therefore, the fact that all dialects of Basque have this type of constructions is just something to be expected, given that all dialects have both *Wh*-movement and sluicing constructions.

Regarding *what type* constructions, the analysis put forth in Irurtzun (2014) suggests that they involve a more complex construction with two CPs and multidominance of the clausal spine, which is dominated by an evidential head. As I said, the availability of this complex structure is restricted to Southern dialects (probably, due to a transfer from Spanish, which also has *what-type* interrogatives like (37), cf. López-Cortina 2003, 2007; Arregi 2007, 2010):

- (37) ¿Qué vienes, [mañana]_F?
 what come tomorrow
 'Is it [tomorrow]_F that you are coming?'
 (Lit. 'What are you coming, tomorrow?')

Northern dialects, on the contrary, cannot make *what*-type split interrogatives.

5. Conclusions

In conclusion, in this chapter I have provided an overview of the different question and focalization strategies available across Basque dialects. We have seen that a core property of Basque syntax is that it treats in a very similar way *Wh*-questions and their answers (focus constructions). The standard strategy (available to all varieties) involves an *A'*-movement of the focal item to Spec-CP (which is accompanied by movement of the verb) but there are also a range of other alternative strategies employed across Basque varieties. These alternative strategies are generally employed in order to gain some semantic nuance (stronger presuppositionality, exhaustivity, etc.) with respect to the standard strategy.

References

- Altube, Seber. 1920. *De sintaxis euskérica*. Donostia: Martin Mena y Cía.
- Arregi, Karlos. 2002. *Focus on Basque movements*. Ph.D. Dissertation: MIT.
- Arregi, Karlos. 2003. "Clausal pied-piping." *Natural Language Semantics* 11: 115–143.
 doi:10.1023/A:1024499226731
- Arregi, Karlos. 2007. "Syntax and semantics of split questions." In *Romance Linguistics 2006. Selected Papers from the 36th Linguistic Symposium on Romance Languages (LSRL)*, José Camacho, Nydia Flores-Ferrán, Liliana Sánchez, Viviane Déprez, and María José Cabrera (eds.), 15–28. Philadelphia: John Benjamins. doi:10.1075/cilt.287.03arr
- Arregi, Karlos. 2010. "Ellipsis in Split Questions." *Natural Language and Linguistic Theory* 28: 539–592. doi:10.1007/s11049-010-9097-x
- Artiagoitia, Xabier. 2000. *Hatsarreak eta Parametroak Lantzen*. Vitoria-Gasteiz: Arabako Foru Aldundia.
- Bošković, Željko. 1998. "LF movement and the Minimalist Program." In *Proceedings of the 28th North East Linguistic Society*, Pius N. Tamanji and Kiyomi Kusumoto (eds.), 43–58. University of Toronto: Graduate Linguistic Student Association.
- Bošković, Željko. 2000. "Sometimes in [Spec, CP], sometimes in situ." In *Step by step*, Roger Martin, David Michaels and Juan Uriagereka (eds.), 53–156. Cambridge: MIT Press.
- Duguine, Maia and Irurtzun, Aritz. 2014. "From obligatory *Wh*-movement to optional *Wh* in situ in Labourdin Basque." *Language* 90.1. doi:10.1353/lan.2014.0006
- Duguine, Maia and Irurtzun, Aritz. 2010. "Opérateurs d'exclusivité dans les questions et réponses en basque." *Revue de Sémantique et Pragmatique* 27: 105–17.

- Eguzkitza, Andolin. 1987. *Topics on the Syntax of Basque and Romance*. Ph.D. Dissertation: UCLA.
- Elordieta, Arantzazu. 2001. *Verb Movement and Constituent Permutation in Basque*. Utrecht: LOT.
- Elordieta, Arantzazu and Haddican, Bill. This volume. "Strategies of Verb and Verb Phrase Focus across Basque Dialects".
- Elordieta, Gorka and Irurtzun, Aritz. 2010. "The relationship between meaning and intonation in non-exhaustive answers: evidence from Basque." *The Linguistic Review* 27.3: 261–291.
- Erdozia, Kepa, Laka, Itziar, Mestres-Missé, Anna and Rodriguez-Fornells, Antoni. 2009. "Syntactic complexity and ambiguity resolution in a free word order language: Behavioral and electrophysiological evidences from Basque." *Brain and Language* 109: 1–17.
doi:10.1016/j.bandl.2008.12.003
- Etxepare, Ricardo. 2014. "The microparameter in Basque participial periphrases." Paper presented at CamCoS 3, University of Cambridge, Cambridge.
- Etxepare, Ricardo. 1998. "A Case for Two Types of Focus in Basque." In *UMOP 21: Proceedings of the Workshop on Focus*, Elena Benedicto, Maribel Romero and Satoshi Tomioka (eds.), 65–81. Amherst, GLSA.
- Etxepare, Ricardo and Ortiz de Urbina, Jon. 2003. "Focalization." In *A Grammar of Basque*. José Ignacio Hualde and Jon Ortiz de Urbina (eds.), 465–522. Berlin and New York: Mouton de Gruyter.
- Etxepare, Ricardo and Uribe-Etxebarria, Myriam. 2004. "In situ wh-phrases in Spanish: locality and quantification." *Recherches Linguistiques de Vincennes* 33: 9–34.
- Hualde, Jose Ignacio, Elordieta, Gorka and Elordieta, Arantzazu. 1994. *The Basque dialect of Lekeitio* [Supplements of ASJU 34]. Gipuzkoako Foru Aldundia and UPV/EHU.
- Irurtzun, Aritz. 2007. *The Grammar of Focus at the Interfaces*. Ph.D. dissertation, University of the Basque Country UPV/EHU.
- Irurtzun, Aritz. 2014. "Euskarazko galdera erdibituak: analisi bitar baterantz." In *Eridenen du zertzaz kontenta. Sailkideen omenaldia Henrike Knörr irakasleari (1947–2008)*. Ricardo Gómez and Mari Jose Ezeizabarrena (eds.), 403–422. Bilbo: UPV/EHU.
- Kiss, Katalin É. (ed.). 1995. *Discourse Configurational Languages*. Oxford: Oxford University Press.
- Lafitte, Piarres. 1944. *Grammaire Basque (Navarro-Labourdin littéraire)*, Revised and corrected edition, Bayonne: Editions des "Amis du Musée Basque" and Ikas.
- Laka, Itziar and Uriagereka, Juan. 1987. "Barriers for Basque and vice-versa." In *Proceedings of NELS 17*, Joyce McDonough and Bernadette Phunkett (eds.), 394–408. Amherst: GLSA.
- López-Cortina, Jorge. 2003. "The structure of split interrogatives." In *Theory, practice, and acquisition: Selected Papers from the 6th Hispanic Linguistics Symposium and the 5th Conference on the Acquisition of Spanish and Portuguese*, Paula Kempchinsky and Carlos-Eduardo Piñeros (eds.), 140–155. Somerville: Cascadilla Press.
- López-Cortina, Jorge. 2007. *The Spanish left periphery: Questions and answers*. Ph.D. Dissertation: Georgetown University.
- Mathieu, Eric. 1999. "Wh in situ and intervention effects." *UCL Working Papers in Linguistics* 11: 441–72.
- Mathieu, Eric. 2004. "The mapping of form and interpretation: The case of optional WH-movement in French." *Lingua* 114.(9–10): 1090–1132.
doi:10.1016/j.lingua.2003.07.002

- Mitxelena, Koldo. 1981. "Galdegaia eta mintzagaia euskaraz." In *Euskal linguistika eta literatura: Bide berriak*, Bilbo: Deustuko Unibertsitatea, 57–81 [Reprinted in *Mitxelenaren euskal idazlan guztiak VI*, 1988, Joseba Andoni Lakarra and Blanca Urgell (eds.), 137–167 Zarautz: Euskal Editoreen Elkarte].
- Obenauer, Hans-Georg. 1994. *Aspects de la syntaxe A-barre. Effets d'intervention et mouvements des quantifieurs*. Thèse d'Etat, Université Paris 8.
- Ortiz de Urbina, Jon. 1989. *Some Parameters in the Grammar of Basque*. Dordrecht: Foris Publications.
- Ortiz de Urbina, Jon. 1993. "Feature percolation and clausal pied-piping." In *Generative Studies in Basque Linguistics*, José Ignacio Hualde and Jon Ortiz de Urbina (eds.), 189–219. Amsterdam: John Benjamins. doi:10.1075/cilt.105.08urb
- Ortiz de Urbina, Jon. 1995. "Residual verb first and verb second in Basque." In *Discourse Configurational Languages*, K. É. Kiss (ed.), 99–121. New York: Oxford University Press.
- Ortiz de Urbina, Jon. 1999. "Force phrases, focus phrases and left heads in Basque." In *Grammatical Analyses in Basque and Romance Linguistics: Papers in Honor of Mario Saltarelli*, Jon Andoni Franco, Alazne Landa and Juan Martín (eds.), 179–194. Amsterdam: John Benjamins. doi:10.1075/cilt.187.11urb
- Ortiz de Urbina, Jon. 2002. "Focus of Correction and Remnant Movement in Basque." In *Erramu Boneta: Festschrift for Rudolf P.G. de Rijk*, Xabier Artiagoitia, Patxi Goenaga and Joseba Andoni Lakarra (eds.), 510–524. Bilbo: Gipuzkoako Foru Aldundia and UPV/EHU.
- Rebuschi, Georges. 1997. "A Note on Focalization in Basque." In *Essais de linguistique basque*. [Supplements of ASJU 35], Georges Rebuschi (ed.), 31–42. Bilbo: Gipuzkoako Foru Aldundia and UPV/EHU.
- de Rijk, Rudolph P.G. 1969. "Is Basque an SOV Language?" *Fontes Linguae Vasconum* 1: 319–351.
- Shlonsky, Ur. 2012. "Notes on Wh In Situ in French." In *Functional Heads: The Cartography of Syntactic Structures*, Volume 7, Laura Brugé et al. (eds.), 242–252. Oxford: Oxford University Press.
- Uriagereka, Juan. 1999. "Minimal restrictions on Basque movements." *Natural Language and Linguistic Theory* 17: 403–444. doi:10.1023/A:1006146705483
- Uribe-Etxebarria, Myriam. 2002. "In situ questions and masked movement." *Linguistic Variation Yearbook* 2: 217–257. doi:10.1075/livy.2.09uri